

# ROUND CYLINDER SERIES RNDC Ø 32 TO 50 mm AND ACCESSORIES

Clean profile cylinders available in different versions:

- configuration with or without magnet
- single- and double-acting - single or through-rod
- pneumatic cushioning on request
- range of gaskets available in NBR, POLYURETHANE and FKM/FPM (for high temperatures).



TECHNICAL DATA	Polyurethane	NBR	FKM/FPM	Low Temperature
Operating pressure	max 10 bar (max 1 MPa - 145 psi)			
Temperature range	-20°C to +80°C (non-magnetic cylinders)	-20°C to +80°C (non-magnetic cylinders)	-10°C to +150°C (non-magnetic cylinders)	-35°C to +80°C
	-20°C to +70°C (magnetic cylinders)	-20°C to +70°C (magnetic cylinders)		
Fluid	Unlubricated air. Lubrication, if used, must be continuous			
Bores	Ø 32; Ø 40; Ø 50			
Design	Screwed heads			
Versions	Double-acting, Double-acting through-rod, Double-acting cushioned, Double-acting through-rod cushioned, Single-acting, Single-acting through-rod.			
Magnet for sensors	All versions come complete with magnet. Supplied without magnet on request			
Standard strokes	Single-acting: for bores Ø32-50 strokes from 0 to 250 mm Double-acting: for bores Ø32-50 strokes from 25 to 500 mm			
Inrush pressure	Ø32 to Ø40: 0.4 bar - Ø50: 0.3 bar			
Forces generated at 6 bar thrust/retraction	See GENERAL TECHNICAL DATA PAGE 1.1/06			
Weights	See GENERAL TECHNICAL DATA PAGE 1.1/05			
	For non-stick slip versions, use unlubricated air only			

## COMPONENTS

- ① PISTON ROD: C45 steel or stainless steel, thick chromed
- ② PISTON ROD GASKET: polyurethane (PARKER PRADIFA), NBR or FKM/FPM
- ③ GUIDE BUSHING: steel strip with bronze and PTFE insert
- ④ JACKET: drawn anodised aluminium alloy
- ⑤ HALF-PISTON: self-lubricating techno-polymer with integrated cushioning olives
- ⑥ MAGNET: in plastoferrite
- ⑦ PISTON GASKET: polyurethane (PARKER PRADIFA), NBR or FKM/FPM
- ⑧ ⑨ HEAD: anodised aluminium alloy

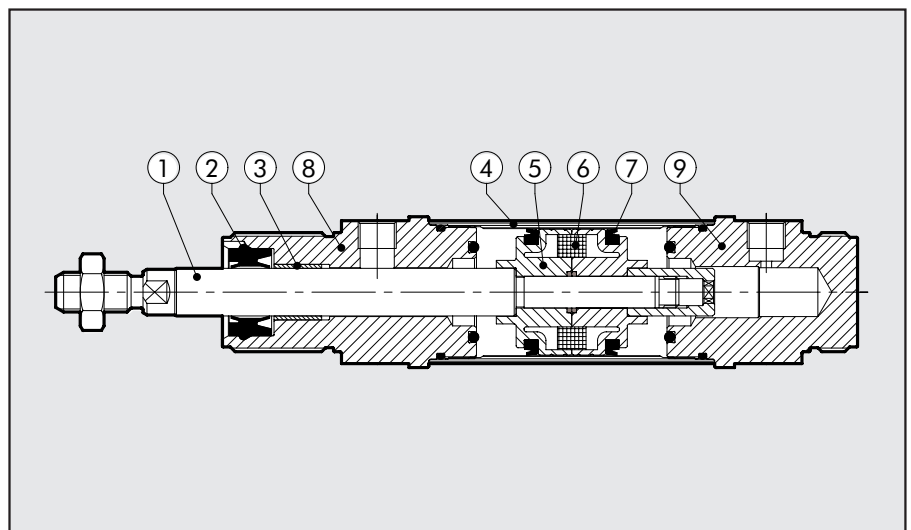



**DIMENSIONS OF STANDARD VERSIONS**

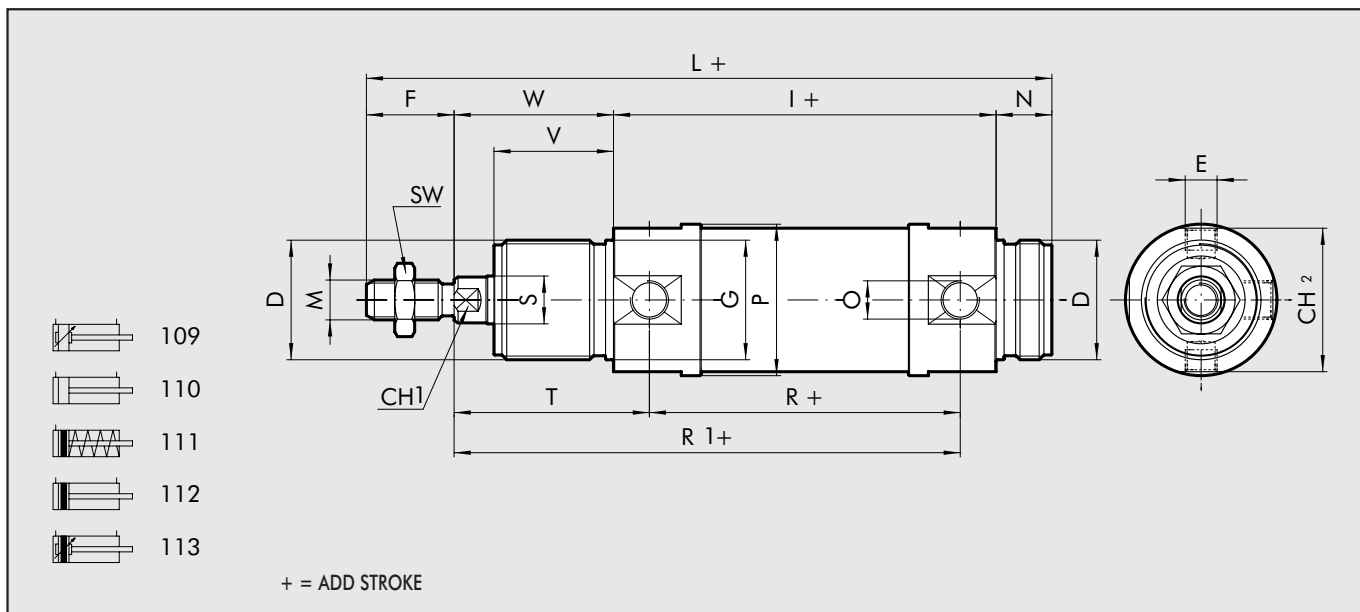

**DIMENSIONS OF THROUGH-ROD VERSIONS**

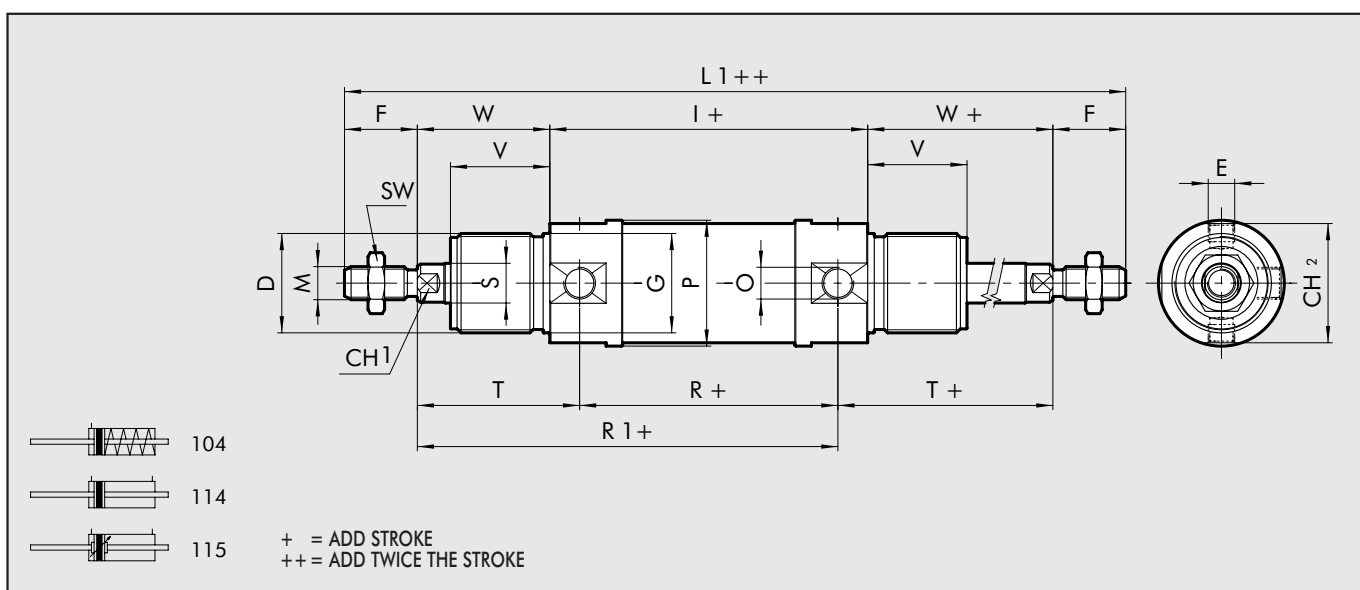

**DIMENSIONS OF STANDARD DOUBLE-ACTING AND THROUGH-ROD**

Ø	D	E	F	ØG	CH1	I	L	M	N	O	ØP	R	ØS	SW	T	CH2	V	W	L1
32	M30x1.5	M8x1	22	30	10	96	172	M10x1.25	14	G1/8	38	78	12	17	49	36	30	40	220
40	M38x1.5	M10x1	24	38	13	113	198	M12x1.25	16	G1/4	46	89	16	19	57	43	35	45	251
50	M45x1.5	M12x1.5	32	45	17	120	220	M16x1.5	18	G1/4	57	96	20	24	62	54	38	50	284

**DIMENSIONS OF STANDARD SINGLE-ACTING AND THROUGH-ROD**

Lower limit	Stroke	Upper limit	I			L			R1			L1		
			Ø 32	Ø 40	Ø 50	Ø 32	Ø 40	Ø 50	Ø 32	Ø 40	Ø 50	Ø 32	Ø 40	Ø 50
0	< C ≤	50	96	113	120	172	198	220	127	146	158	220	251	284
50	< C ≤	100	125	145.5	155.5	201	230.5	255.5	156	178.5	193.5	249	283.5	319.5
100	< C ≤	150	154	178	191	230	263	291	185	211	229	278	316	355
150	< C ≤	200	183	210.5	226.5	259	295.5	326.5	214	243.5	264.5	307	348.5	390.5
200	< C ≤	250	212	243	262	288	328	362	243	276	300	336	381	426

For all the other values, see previous table, except for T and R which are both replaced by R1.

## KEY TO CODES

CYL	1	1	2	0	3 2	0 0 2 5	C	P		
	TYPE				BORE	STROKE				
	■ 104	SE axial coupling		0	Standard	32	+	A	C45 chrome rod, aluminium piston rod	P polyurethane
	109	DEA		▲ G	No stick slip	40		C	C45 chrome rod, technopolymer piston rod	N NBR
	110	DE		S	Non-magnetic	50		Z	Stainless steel piston rod and nut	● V FKM/FPM
	■ 111	SE						X	Stainless steel piston rod and nut	● B low temperature
	112	DEM								
	113	DEMA								
	114	DEM through-rod								
	115	DEMA through-rod								

DE: Double-acting (non-cushioned, not magnetic)  
 DEM: Magnetic double-acting (non-cushioned)  
 DEMA: Magnetic double-acting (cushioned)  
 DEA: Cushioned double-acting (non-magnetic)  
 SE: Single-acting (magnetic)

● Only available for non-magnetic versions (S) and with aluminium piston (A or Z)  
 + Maximum recommended strokes. Higher values can create operating problems  
 ▲ Not available for NBR (N) versions  
 ■ Only available for versions with aluminium piston (A or Z)

## NOTES

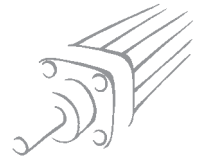

# ACCESSORIES: FIXINGS

1

## LEGS MODEL AC

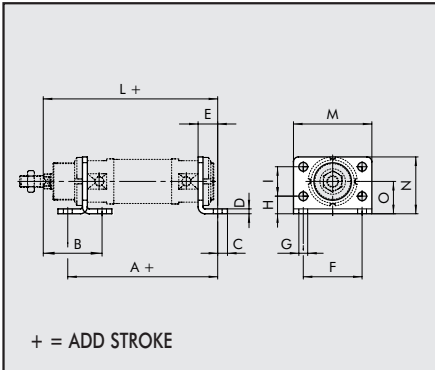

Code	Ø	A	B	C	D	E	F	G	H	I	L	M	N	O	Weight [g]
W0950320002	32	124	50	7	4	14	52	7	14	28	150	66	49	28	104
W0950400002	40	153	60	10	5	20	60	9	18	30	178	80	58	33	190
W0950500002	50	160	64	10	6	20	70	9	20	40	190	90	70	40	296

Note: Individually packed

## COUNTER-HINGE MODEL BC

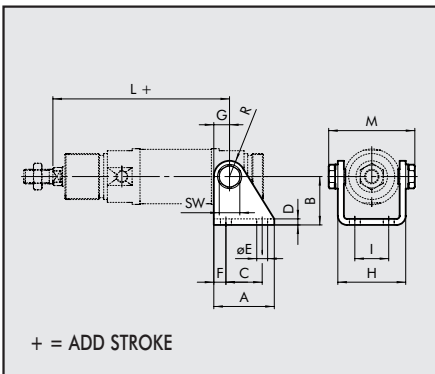

Code	Ø	A	B	C	D	E	F	G	H	I	L	M	R	SW	Weight [g]
W0950320005	32	40	35	24	4	7	8	12	46.1	20	127	60	12	13	152
W0950400005	40	50	40	30	5	9	10	13	56.1	28	146	72.5	13	17	262
W0950500005	50	54	45	34	6	9	10	14	69.1	36	158	89	14	19	401

Note: Supplied with 2 screws

## HEAD RING NUT MODEL G

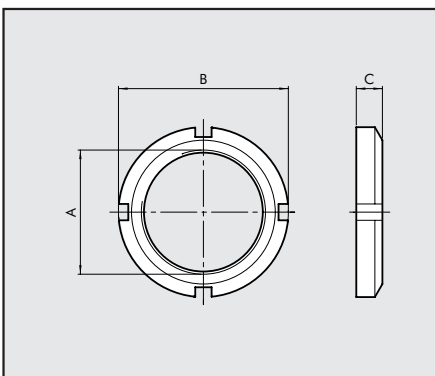

Code	Ø	A	B	C	Weight [g]
W0950320010	32	M30x1.5	45	7	46
W0950400010	40	M38x1.5	50	8	56
W0950500010	50	M45x1.5	58	9	126

Note: Individually packed

## FORK MODEL GK-M

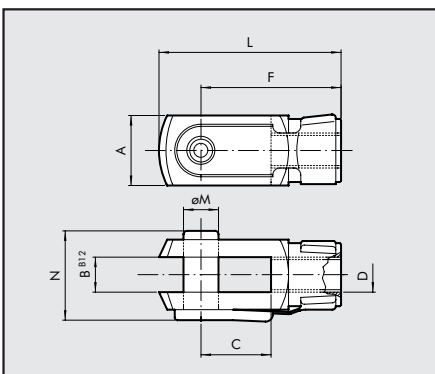

Code	Ø	Ø M	C	B	A	L	F	D	N	Weight [g]
W0950322020	32	10	20	10	20	52	40	M10x1,25	26	92
W0950402020	40	12	24	12	24	62	48	M12x1,25	32	148
W0950502020	50	16	32	16	32	83	64	M16x1,5	40	340

Note: Individually packed

### SPHERICAL JOINT MODEL GA-M

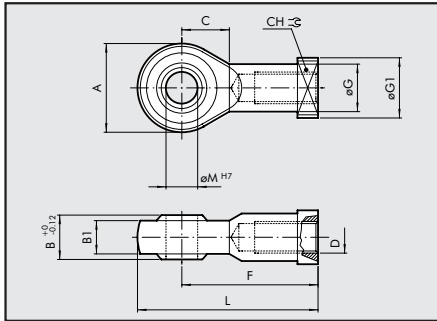

Code	Ø	Ø M	C	B1	B	A	L	F	D	Ø G	CH	Weight [g]
W0950322025	32	10	15	10,5	14	28	57	43	M10x1,25	15	17	78
W0950402025	40	12	17	12	16	32	66	50	M12x1,25	17,5	19	116
W0950502025	50	16	22	15	21	42	85	64	M16x1,5	22	22	226

Note: Individually packed

### ARTICULATED JOINT MODEL GA-K

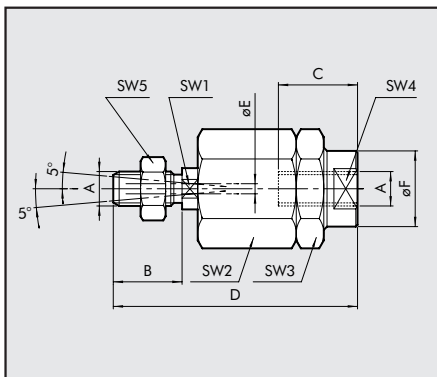

Code	Ø	A	B	C	D	Ø E	Ø F	SW1	SW2	SW3	SW4	SW5	Weight [g]
W0950322030	32	M10x1,25	20	20	71	4	22	12	30	30	19	17	216
W0950402030	40	M12x1,25	24	20	75	4	22	12	30	30	19	19	220
W0950502030	50	M16x1,5	32	32	103	4	32	20	41	41	30	24	620

Note: Individually packed

## ACCESSORIES: MAGNETIC SENSORS

### SENSOR

### ORDERING CODES

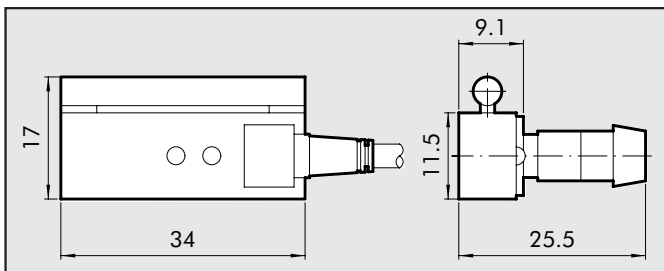

Codes	Description
MAGNETIC PROXIMITY SENSORS	
W0950000201	REED SENSOR ACC. DSM2 - C525
W0950000222	E. HALL PNP SENSOR ACC. DSM3-N225
W0950000232	E. HALL NPN SENSOR ACC. DSM3-M225

N.B.: For technical data on sensors, see Accessories for ISO 6431 cylinders, page 1.1/61

### SENSOR CIRCLIP

Code	Model	Bore	Ø	A	B
------	-------	------	---	---	---

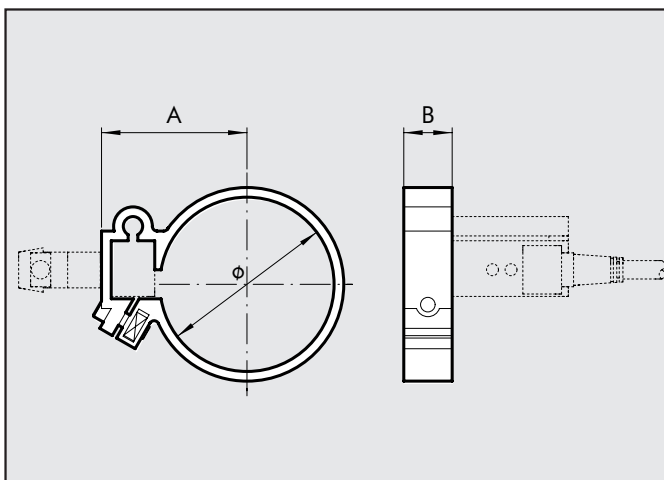

W0950000132	CIRCLIP DXF 36- 32	32	36	29.5	10
W0950000140	CIRCLIP DXF 45- 40	40	45	34.5	10
W0950000150	CIRCLIP DXF 52- 50	50	55	38.5	10